

65TiG25 Assembly

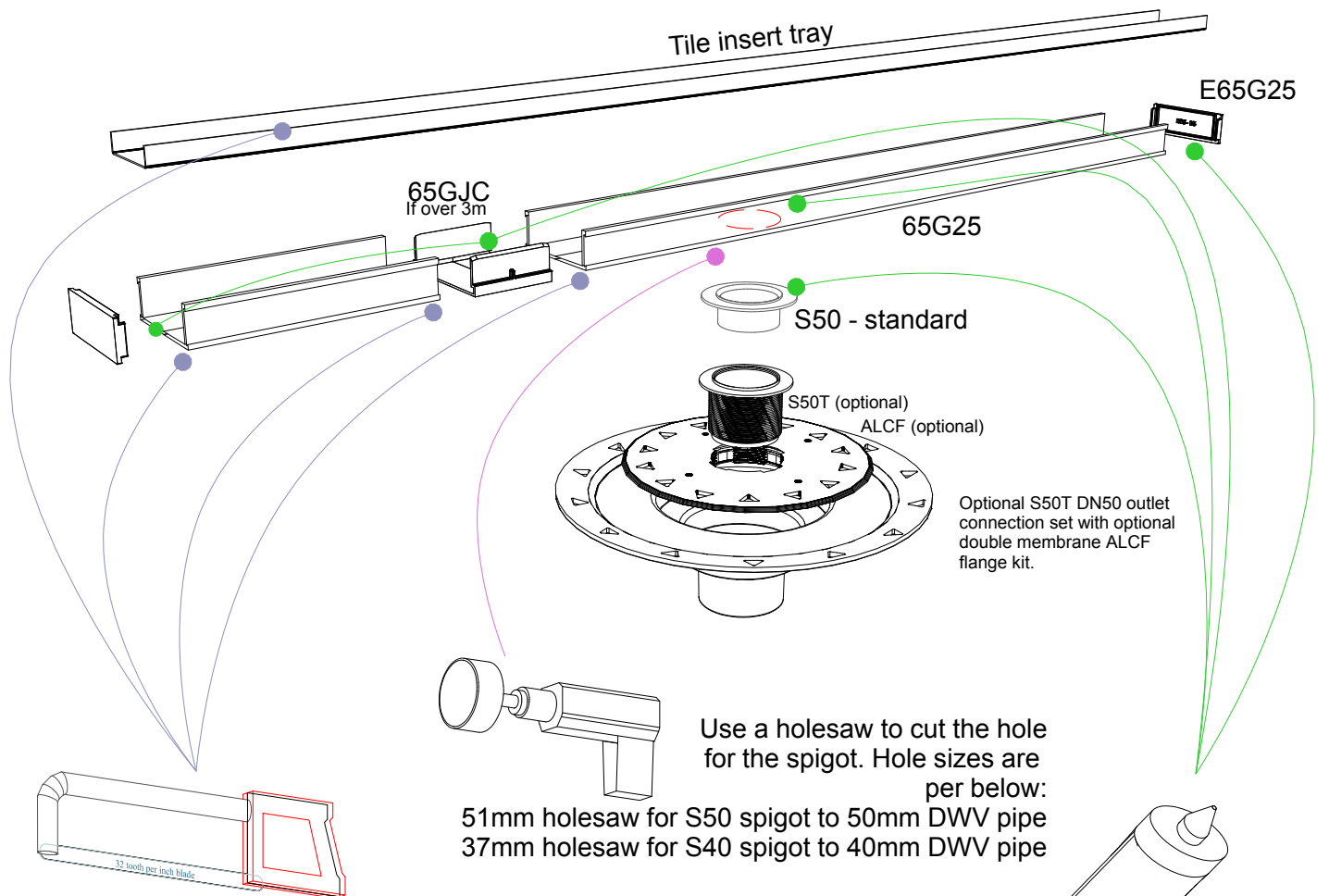

NOTE, maximum run not longer than 2.0m



Use a hacksaw with 32TPI blade to cut both stainless insert tray and PVC channel.
NOTE, cut the insert tray AFTER the CHANNEL is ASSEMBLED. The insert tray will be SHORTER to fit INSIDE the channel.

PVC solvent cement the parts together. Use type N clear with clear primer.

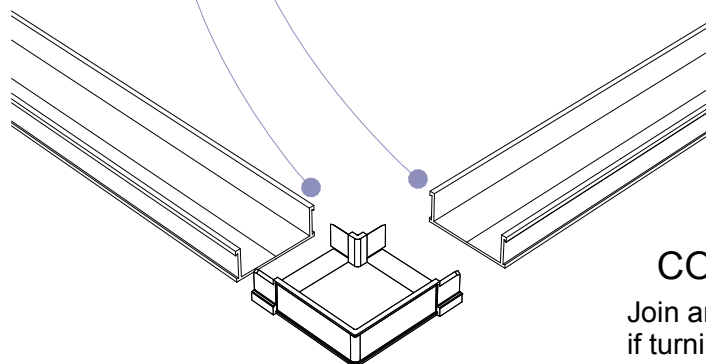

CORNERS

Join angles as shown if turning channel around a 90 degree corner.

